

Now, the competitive edge of supercomputing is within reach.

The CRAY Y-MP EL Supercomputer System



CRAY
RESEARCH, INC.



Introducing the CRAY Y-MP EL Supercomputer System

As the maker of the world's most powerful and highest-quality computational tools, Cray Research has been giving scientists and engineers the competitive edge for over 15 years. To bring this capability to a broader range of users, Cray Research has developed the CRAY Y-MP EL system — the most affordable supercomputer we've ever offered.

Extending the range of supercomputing excellence

The CRAY Y-MP EL system delivers unmatched throughput performance in its price range by incorporating all the advantages of our powerful and balanced CRAY Y-MP architecture. With up to four CPUs working in parallel with up to 1024 Mbytes of central memory, the CRAY Y-MP EL provides the highest possible performance on a wide variety of applications. But its computational power doesn't stop there. As your problem-solving needs grow, the CRAY Y-MP EL provides a cost-effective pathway to the computational power of large-scale supercomputing.

High performance made accessible

Until now, the cost of supercomputing often exceeded the means of many who could benefit from this technology. The CRAY Y-MP EL computer system makes superior performance more affordable by significantly reducing the cost of acquiring, installing, operating, and maintaining a real Cray Research supercomputer.

Because it is air-cooled and uses less than 6 kW of power per cabinet, the CRAY Y-MP EL can be installed in an air conditioned office environment. It has a limited number of connections, making installation quick and easy.

A total supercomputing solution

At Cray Research, we offer a total supercomputing solution with outstanding performance and functionality. The CRAY Y-MP EL supercomputer works with Cray Research software, applications, and customer networks, allowing you to focus on science and engineering — not the system's requirements.

The CRAY Y-MP EL system is upwardly and downwardly compatible with other members of the CRAY Y-MP supercomputer family. All Cray Research systems run UNICOS, a powerful UNIX-based operating system optimized for maximum performance on production workloads. With outstanding functionality, performance, and ease of use, UNICOS is the most powerful and feature-rich operating system available for technical computing.

The CRAY Y-MP EL system offers performance-oriented software products that enhance its capabilities. From industry-leading compilers to powerful performance optimization tools, Cray Research software ensures that you will get the highest possible performance from your CRAY Y-MP EL system.

Cray Research systems are unsurpassed in their ability to connect to computer hardware from other vendors. The CRAY Y-MP EL conforms to industry standards and supports a variety of language extensions and tools from other vendors, so your existing network investments are protected. The result is an optimum computing environment with a wider range of resources that improves user productivity.

The CRAY Y-MP EL system

High-performance functionality

The CRAY Y-MP EL supercomputer features a powerful, balanced architecture that provides the highest possible performance in its class on scientific and engineering applications. In addition to departmental supercomputing, it also can be used in the following ways:

- As a complementary system for larger Cray Research systems.* The CRAY Y-MP EL is ideal for UNICOS application development. Because binaries from the CRAY Y-MP EL system will run on other CRAY Y-MP systems, work is easily scaled to larger Cray Research systems.
- As a secure system.* Because it is physically compact and offers removable storage media, the CRAY Y-MP EL

is ideal for secure processing environments. UNICOS also provides multi-level security.

- As a high-performance file server.* Combined with the powerful data management features of the UNICOS operating system, the CRAY Y-MP EL system is an excellent file server platform. With support for stand-alone STK autoloading tape cartridge systems, the CRAY Y-MP EL file server can satisfy requests from multiple supercomputers over gigabit/second networks while providing service to smaller systems, workstations, and personal computers. When used as a file server, the CRAY Y-MP EL system may also simultaneously perform scientific processing.

Advantages of affordable supercomputing

The CRAY Y-MP EL system provides the following benefits without compromising performance:

- Unmatched price/performance.* The CRAY Y-MP EL offers more computing power for the money by offering the most throughput performance in its price range for multi-user technical computing.
- Extensive connectivity.* The CRAY Y-MP EL system will connect easily to your existing network; it offers extensive connectivity to a wide variety of mainframes, minicomputers, and workstations.
- Full functionality.* The CRAY Y-MP EL system can be a cost effective departmental supercomputer platform or a node in a heterogeneous networking environment.
- Upward compatibility.* The entire CRAY Y-MP product line is binary compatible, providing a seamless pathway from the CRAY Y-MP EL system to the world's most powerful supercomputer systems. This binary compatibility saves time and provides users and administrators with more control and consistency throughout the supercomputing environment.
- Easy access to high performance.* The CRAY Y-MP EL system runs the same powerful operating system, UNICOS, the same Autotasking/autovectorizing compilers, and the same library of software applications as other members of the CRAY Y-MP family.
- Cost effectiveness.* The CRAY Y-MP EL supercomputer system is compact, easy to install, and inexpensive to operate. Its low power requirements, high reliability, and minimal service requirements reduce operating costs.



Supercomputers are used to simulate physical phenomena that would be difficult or impossible to create experimentally. These simulations provide the necessary insight to reduce design cycles and produce innovations.

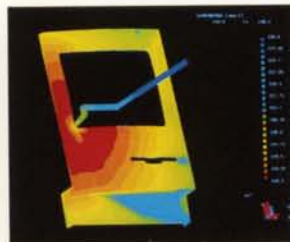

Left, flow front distribution in an injection-molded plastic computer case modeled with MOLDFLOW. Molding is an Apple Macintosh Classic front bezel.

Right, fluid temperature pattern within a beer bottle as it is heated during pasteurization in order to sterilize beer, simulated with the FIDAP fluid dynamics program.

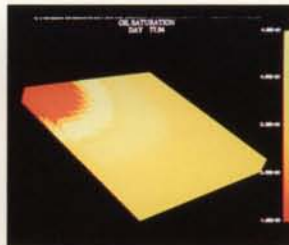

Left, simulated oil saturation in a quarter-five-spot model of a petroleum reservoir undergoing a chemical flood-enhanced recovery process. Image is displayed in three dimensions utilizing MPGS.

Proven, balanced architecture ensures high performance

The CRAY Y-MP EL system combines a proven architecture with innovations that provide the highest level of sustained performance in its price range. Using the integrated vector CRAY Y-MP architecture, each CPU provides balanced scalar, vector, memory, and I/O performance. To enhance performance while preserving binary compatibility, the CRAY Y-MP EL includes an innovative multifunctional unit extension to this architecture that provides up to four results per clock period (instead of two). To enhance

performance even further, the CRAY Y-MP EL CPU is designed to maximize the overlapping of vector, scalar, memory, and I/O operations.

Configurations to fit present needs, with room to grow

The CRAY Y-MP EL can be upgraded easily in the field. The standard CRAY Y-MP EL configuration consists of a single cabinet containing the CPU(s), memory, and one to four VME-based I/O Subsystems connected to disk subsystems or disk array subsystems, tape systems, and networking systems. Over 40 Gbytes of disk storage capacity can reside in the main cabinet. Up to three I/O peripheral cabinets may be added to provide up to 16 VME I/O Subsystems and over 200 Gbytes of disk storage capacity.

CRAY Y-MP EL Product Specifications

CPU

Technology	CMOS
Clock period	30 ns
Number of CPUs	1 - 4
Peak performance (per CPU)	133 MFLOPS

Memory

Memory ports	4 per CPU
Technology	70 ns CMOS DRAM
Memory size	256 - 1024 Mbytes (32 - 128 Mwords)
Memory bandwidth per CPU	1.05 Gbytes/sec
Total memory bandwidth	4.2 Gbytes/sec
Memory banks	64, regardless of memory size

I/O

Number of I/O Subsystems	1 - 4 per CPU
I/O bandwidth per CPU	264 Mbytes/sec
Total system I/O bandwidth	1.05 Gbytes/sec
Total VME bandwidth	640 Mbytes/sec
HIPPI	100 Mbytes/sec each

Physical characteristics (per cabinet)

Weight	1400 lbs (635 kg)
Area	11 ft ² (1 m ²)
Maximum power consumption per cabinet	6 kW (6 kVA)
Operating temperature	50° - 85° F (10° - 35° C)

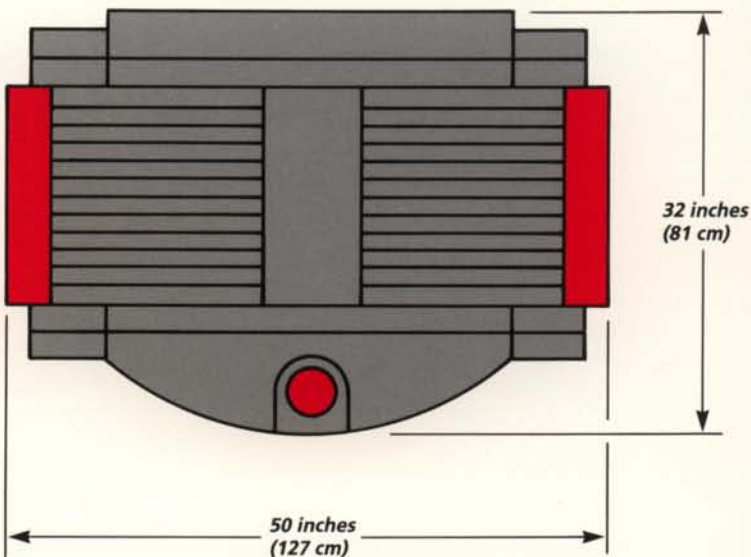

High-performance I/O

VME I/O subsystem

As with all CRAY Y-MP systems, the CRAY Y-MP EL offers the best I/O performance in its class. The IOS allows the central memory of the CRAY Y-MP EL system to communicate at high speeds with networks and peripherals such as disk storage units and tape units, while off-loading this activity from the CPU.

The CRAY Y-MP EL system uses industry-standard VME-based I/O subsystems that connect to a wide variety of peripherals and networks. The VME I/O subsystem is an integral part of the CRAY Y-MP EL design, acting as the mainframe's data distribution point.

The VME I/O technology is extremely versatile; it provides customers with a flexible computing platform that can grow with their I/O and peripheral needs. The standard configuration of the CRAY Y-MP EL system includes one VME I/O subsystem. Additional VME I/O subsystems can easily be configured at customer sites.

To increase the CRAY Y-MP EL production workload capacity, the CRAY Y-MP EL system has an aggregate VME I/O bandwidth of up to 640 Mbytes/sec to peripheral devices. This large bandwidth allows users to access more peripheral devices and perform more simultaneous activities.

Cray Research supports a wide range of peripheral and network devices to meet your performance, capacity, and budgetary needs. To provide high-speed access to data, the CRAY Y-MP EL supports disk drives with transfer rates of up to 18 Mbytes/sec as well as high-performance online tapes and stand-alone STK 4400 tape cartridge autoloaders.

VME I/O subsystem highlights

- Up to 4 VME I/O subsystems per CPU
- 40 Mbyte/sec bandwidth per VME
- 160 Mbyte/sec VME I/O bandwidth per CPU
- Aggregate VME I/O bandwidth of 640 Mbytes/sec

Software

Performance-oriented, feature-rich software

The Cray Research application support environment is a complete body of performance-oriented system software that enables users to focus on their work, not the system's requirements. As part of a total system solution, the application support environment includes UNICOS, the world's first UNIX-based supercomputer operating system, as well as a set of powerful compilers, development tools, high-performance libraries, and data storage systems.

UNICOS operating system

UNICOS is the most powerful and feature-rich UNIX-based operating system available to supercomputer users. Based on the UNIX System V operating system with Berkeley extensions and performance enhancements, UNICOS is an interactive and batch operating system that offers a number of advantages including high performance, full functionality, portability, and connectivity.

UNICOS features hundreds of programmer years of optimizations that deliver very high performance on production workloads. Together with the powerful CRAY Y-MP EL computer hardware and Autotasking capabilities, this performance not only provides fast turnaround on individual jobs, but also high throughput for a varied workload through sophisticated job scheduling capabilities.

UNICOS combines all the inherent strengths of UNIX, such as a familiar user interface, with production-oriented features including high-performance I/O, optimal memory bandwidth utilization, multiprocessing support, ANSI/IBM tape support, resource control, sophisticated job scheduling, tunable accounting, and batch processing.

Peripheral highlights

- Individual disk speeds of 2.75, 9.3, and 18 Mbytes/sec
- Main memory ldcache increases file system efficiency
- Provides fast single file access disk striping
- Tape drives supported include: 1/4 inch cartridge; 5 Gbytes, 8 mm; 125 ips, 9 track; IBM 3480-compatible

Right, crystal growth of silicon calculated using the code MHD2DTA.

Far right, blood flow velocity magnitude vectors in a bifurcated vessel simulated with the FIDAP fluid dynamics program.

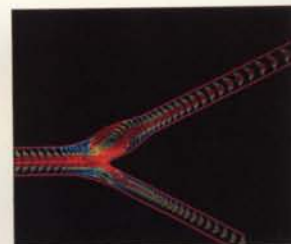
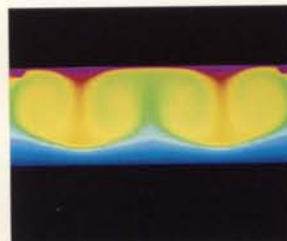

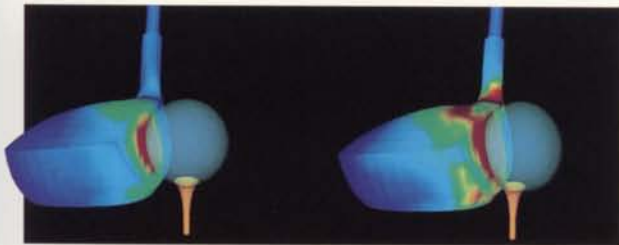

Left, stresses in a titanium metal driver at a particular instant as it strikes a golf ball at 100 miles per hour, simulated using the MSC/DYNA finite element program; data visualized with the MPPGS postprocessing environment. Simulations such as this can be used to help design stronger, more lightweight clubs.

Compilers

Cray Research offers the most powerful compilers in the industry, including the CF77 Fortran compiling system, the Cray Standard C Compiler, Cray Ada, and Pascal.

The CF77 compiling system was the first Fortran compiler in the industry with the functionality required for automatic parallel processing, automatic vectorization, and scalar optimization. These compiling features typically require little or no code modification by the user, and full optimization is turned on by default.

The CF77 compiling system ensures portability with full compliance to ANSI standard 3.9-1978. The flexibility of CF77 allows it to accept many nonstandard constructs written for IBM, DEC, CDC, and other vendors' compilers.

The CF77 compiling system compiles Fortran77 programs into executable code modules that take full advantage of the CRAY Y-MP EL vector capabilities, while its Autotasking feature further enhances performance on multiprocessor systems.

For those codes that are not highly vectorizable, CF77 ensures the best possible execution time by providing scalar optimization for the CRAY Y-MP EL system.

Because supercomputing applications written in the C language are becoming increasingly popular, Cray Research offers the highest-performance ANSI standard C compiler in the industry. The Cray Standard C compiler can be used to create portable, highly optimized code with performance comparable to Fortran programs. Like CF77, the Cray Standard C compiler takes full advantage of the CRAY Y-MP EL performance capabilities with automatic vectorization, scalar optimization, and Autotasking.

- Removable disk drives
- Support for high-speed and low-speed networks (Ethernet, HYPERchannel, and FDDI)
- Support for STK 4400 tape autoloaders
- Support for the ANSI standard HIPPI channel
- Centronics-compatible printers
- Plotters for seismic applications

Right, the ANSYS program was used to solve this linear elastic problem; colors signify the Von Mises stresses on the component — a tool holder.

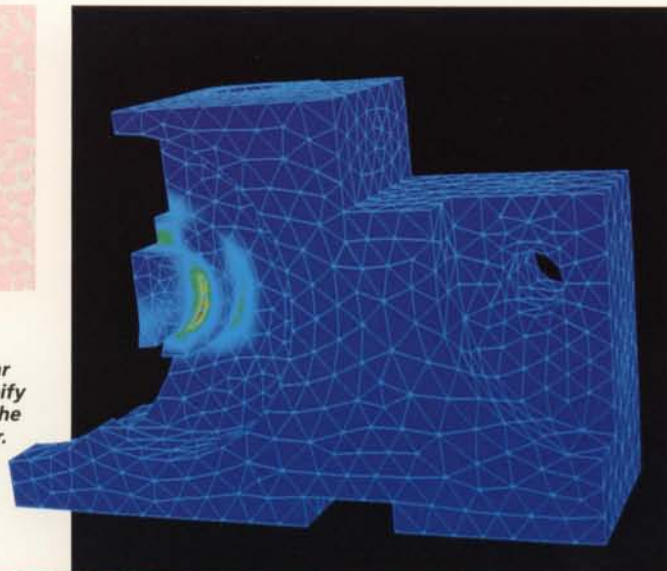

UNICOS highlights

Full functionality

- Batch processing
- High-speed tape support
- Resource management
- Accounting
- Checkpoint/restart
- Networking
- Data Migration Facility (DMF)
- Online system diagnostics
- Multi-level security

High performance

- Autotasking and autovectorizing features
- Efficient I/O
- File system extensions

Ease of use

- Advanced program development tools
- X Window System support
- Performance analysis tools

Autotasking

The CF77 compiling system and the Cray Standard C Compiler include Autotasking features that can dramatically improve performance on multiprocessor CRAY Y-MP EL systems. The Autotasking feature divides a program into discrete tasks that can be performed concurrently on all processors in the CRAY Y-MP EL system. The Autotasking features also include a convenient, powerful set of directives that allow programmers to fine-tune their code for even better performance. In production environments, this feature can be used to improve individual jobs and overall system throughput.

UNICOS Storage System

The UNICOS Storage system is the world's first high-performance UNIX-based file server. With the UNICOS Storage System, the CRAY Y-MP EL system enables users to meet their computing needs while addressing the file storage needs of their network. The UNICOS Storage System provides transparent data access, file access capabilities, system administration, and automated storage management capabilities.

Applications

Cray Research offers leading-edge applications for nearly every scientific and engineering discipline, including the most widely used third-party application programs. These applications are used by diverse industries to accelerate product development, increase productivity, and solve basic research problems. Applications are available for industries such as aerospace, automotive, chemistry, energy, petroleum, and defense.

The power of visualization

Cray Research offers the following software packages to couple the power of visualization with its supercomputers:

- Multipurpose Graphic System (MPGS)*, an interactive menu-driven engineering visualization package for use on Cray Research computer systems. MPGS works with a wide variety of engineering applications.
- UniChem*, Cray Research's easy-to-use supercomputing environment for computational chemistry simulation that enables researchers to explore complex chemical systems at a new level of detail from their desktops.
- The Cray Visualization Toolkit (CVT)*, which enables users to run applications on Cray Research systems through their workstations. CVT allows users to generate graphics and user interfaces easily with the following tools:
 - Release X11R4 of the X Window System
 - Sun Microsystems' XView toolkit (OPEN LOOK)
 - Open Software Foundation's (OSF) Motif 1.1 Toolkit
 - Silicon Graphics, Inc. Distributed Graphics Library (DGL)

These tools allow most applications that run on Cray Research Systems to have the same "look and feel" as the most common workstation environments, making Cray Research systems even easier to use and making users more productive.

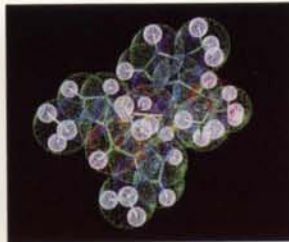
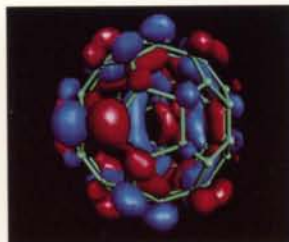

Cray Research's UniChem computational chemistry environment allows researchers to build, calculate, and visualize complex chemical systems. Far left, lowest unoccupied molecular orbital (LUMO) for the C-60 molecule (Buckminsterfullerene). Left, density functional model of

a copper imidazole complex displayed with a Van der Waals surface.

Delivering supercomputing power to your desktop

To bring the benefits of supercomputing to more users than ever before, Cray Research is dedicated to making its systems accessible through Network Supercomputing. Because Cray Research supercomputers support industry standards as well as a variety of language extensions and utilities from other vendors, they can be integrated easily into heterogeneous computing environments.

An array of communication products and protocols supported by Cray Research allows applications to be distributed within your network. Through the implementation of emerging and de facto networking standards, Cray Research provides connectivity to most UNIX-based mainframes, minicomputers, and workstations. These

standards include the TCP/IP networking protocol and applications, the X Window System, the Network File System, the Open Systems Interconnect (OSI) of the International Standards Organization (ISO), the High Performance Parallel Interface (HIPPI), the Fiber Distributed Data Interface (FDDI), as well as other networking standards.

Network Supercomputing increases user productivity by allowing access to a wide range of computing platforms for optimal workload distribution. The result is a combination of flexibility and computing power unparalleled in the computer industry.

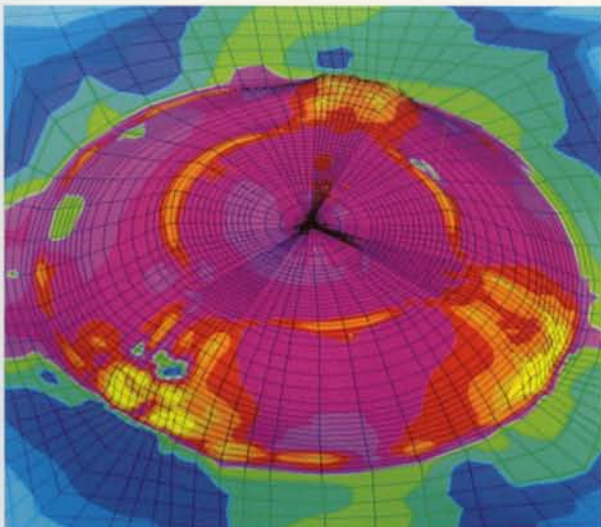
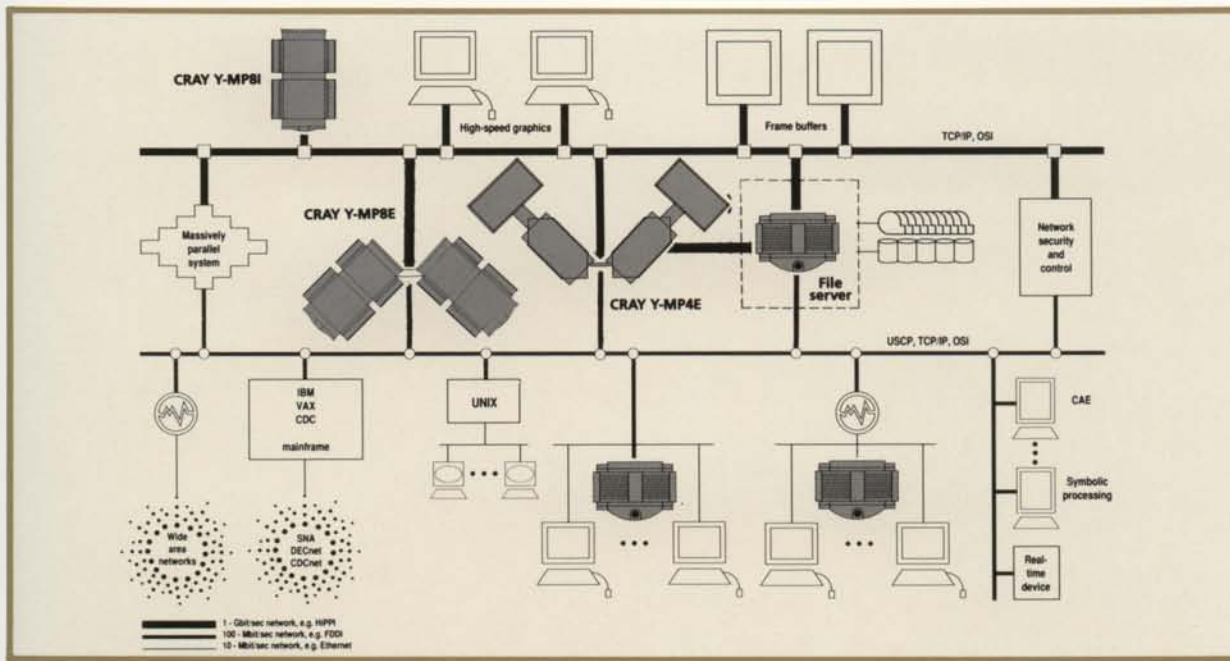

Left, equivalent plastic strain distribution during sheet metal forming, simulated with the MARC finite element analysis program.

Supercomputing excellence within reach

Maximized system availability

The CRAY Y-MP EL supercomputers provide high system reliability while maintaining high performance. System quality begins with a design process that integrates quality and reliability into every system component. Before shipment, your CRAY Y-MP EL computer system undergoes rigorous operational and reliability tests.

Cray Research offers a wide range of maintenance options for the CRAY Y-MP EL system to meet your needs. To assure high system availability, Cray Research has developed advanced system support tools including the new System Maintenance and Remote Test Environment (SMARTe), which provides continuous error detection and isolation.

The CRAY Y-MP EL system

The CRAY Y-MP EL system brings supercomputing excellence within reach with outstanding performance and price/performance. As with all CRAY Y-MP systems, it excels in a wide range of applications. Backed by Cray Research's unmatched experience with total supercomputing solutions, the CRAY Y-MP EL system gives you the power to sharpen your competitive edge.

For more information on the CRAY Y-MP EL supercomputer, contact your local Cray Research representative.



Above, scientific data enhancement using the AVS visualization system. An output from the ABAQUS finite element analysis program is integrated into an AVS network for analysis

of the stress levels within each hexahedron cell of the structure. AVS provides a visual point-and-click interface to computing modules on both the workstation and the Cray Research system.

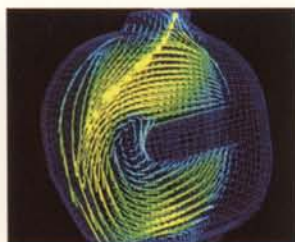

Left, airflow velocity and fuel injection in an indirect injection diesel engine simulated with Cray Research's CRI/TurboKiva engineering program.

Right, a port fuel-injected, four-valve combustion chamber of a gasoline engine simulated with the CRI/TurboKiva combustion engineering program. Here, the air intake and injection of fuel are modeled.

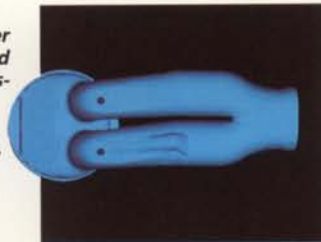





655-A Lone Oak Drive
Eagan, MN 55121
(612) 683-3801

Image credits in the order they appear:

Computer case image courtesy of Apple Computer, Inc. Beer pasteurization image courtesy of Dr. Michael Engelman, Fluid Dynamics International. Simulation of oil saturation done using UTCHEM, developed by the Department of Petroleum Engineering at the University of Texas. Crystal growth image courtesy of Branko Kosovic, Penn State University. Blood vessel image courtesy of Dr. Clement Kleinstreuer, North Carolina State University. Titanium driver images from an animation produced by Cray Research, MacGregor Golf Company, and the MacNeal-Schwendler Corporation. Sheet metal forming image courtesy of MARC Analysis Research Corporation. AVS image courtesy of Stardent Computer, Inc., and ABAQUS data courtesy of Hibbitt, Karlsson, and Sorensen, Inc. Gasoline combustion chamber image courtesy of Nissan Motor Co., Ltd.

CRAY, CRAY Y-MP, and UNICOS are federally registered trademarks, and CF77, CRAY Y-MP EL, CRI/TurboKiva, MPGS, and UniChem are trademarks of Cray Research, Inc.

ABAQUS is a trademark of Hibbitt, Karlsson & Sorensen, Inc. ANSYS is a trademark of Swanson Analysis, Inc. Apple Macintosh is a trademark of Apple Computer, Inc. AVS is a trademark of Stardent Computer, Inc. Ethernet is a trademark of Xerox Corporation. FIDAP is a trademark of Fluid Dynamics International. FLUENT is a trademark of create.x Inc. HYPERchannel is a trademark of Network Systems Corporation. MARC is a trademark of MARC Analysis Research Corporation. MSC/DYNA is a trademark of the MacNeal-Schwendler Corporation. SunView is a trademark of Sun Microsystems, Inc. The Cray Research implementation of TCP/IP is based on a product from the Wollongong Group, Inc. UNIX, System V, and OPEN LOOK are trademarks of UNIX System Laboratories, Inc. X Window System is a trademark of the Massachusetts Institute of Technology.

The product specifications contained in this brochure and the availability of the products are subject to change without notice. For the latest information, contact your Cray Research representative.